

Area of a Triangle $\left(\frac{1}{2}ab \sin C\right)$ www.m4ths.com

(1) Find the area of each triangle giving your answers to 1 decimal place where appropriate.

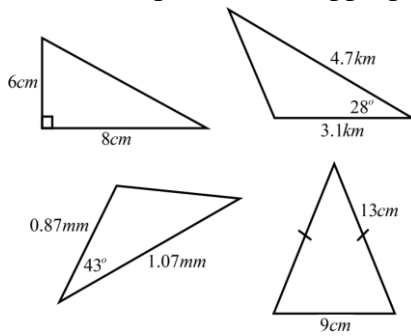

(2) Find the area of each triangle below giving your answer to 1 decimal place. Be careful with one of them! (Hint.....Cosine...)

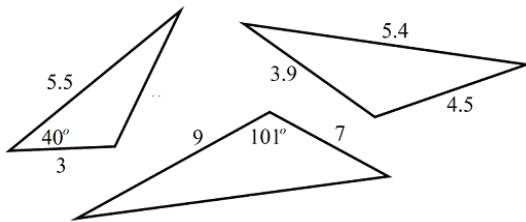

(3) Find the area of each triangle below giving your answer to 1 decimal place. You may need to do some work on them first!

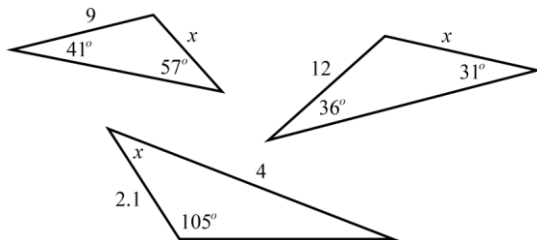

(4) The diagram below shows a square with a triangle attached to one side. The triangle and the square share one side length. Given that the area of the square is $49cm^2$, find the area of the triangle as a percentage of the area of the square. Round your answer to the nearest one percent.

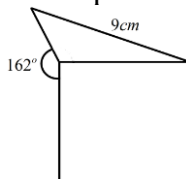

(5) Below is a picture of the isosceles trapezium $ABCD$. The line BX is perpendicular to the line DC , $\angle BAX = 43^\circ$ and $\angle ADX = 79^\circ$.

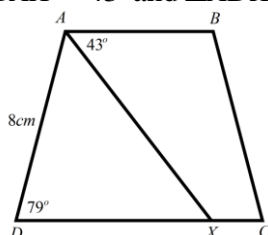

- Find the length of the line AX .
- Find the area of $\triangle ADX$
- Find the area of the quadrilateral

Area of a Triangle $\left(\frac{1}{2}ab \sin C\right)$ www.m4ths.com

(1) Find the area of each triangle giving your answers to 1 decimal place where appropriate.

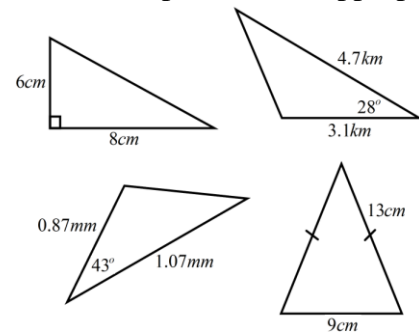

(2) Find the area of each triangle below giving your answer to 1 decimal place. Be careful with one of them! (Hint.....Cosine...)

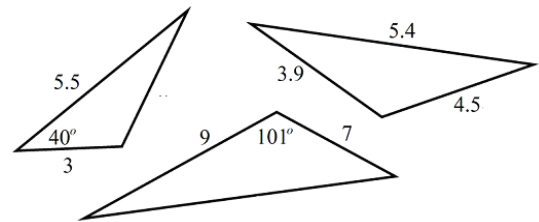

(3) Find the area of each triangle below giving your answer to 1 decimal place. You may need to do some work on them first!

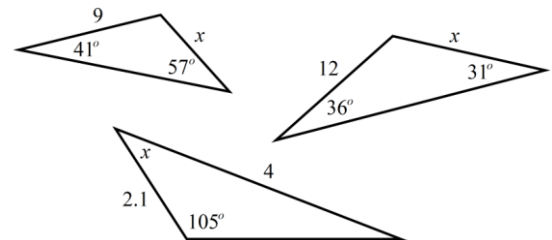

(4) The diagram below shows a square with a triangle attached to one side. The triangle and the square share one side length. Given that the area of the square is $49cm^2$, find the area of the triangle as a percentage of the area of the square. Round your answer to the nearest one percent.

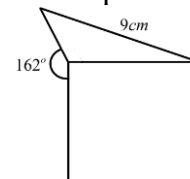

(5) Below is a picture of the isosceles trapezium $ABCD$. The line BX is perpendicular to the line DC , $\angle BAX = 43^\circ$ and $\angle ADX = 79^\circ$.

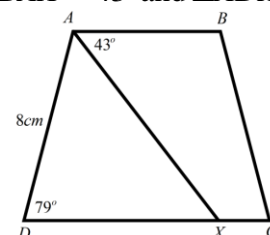

- Find the length of the line AX .
- Find the area of $\triangle ADX$
- Find the area of the quadrilateral