

GCSE Higher ‘Wordy’, Problem Solving and ‘Enjoying Maths’ Questions.
(Version 2 – 120 Questions)

Name _____

Class _____

Target Grade _____

Grade I want to (and working to) achieve _____

Career Ambition

Please feel free to use this in schools and colleges.

If you would like to make a donation to help keep www.m4ths.com running, please visit the site. This can be done through Paypal.

Problem Solving GCSE Questions 1

www.m4ths.com

(1) Ann, Bettie and Carol are sisters. They are driving home from work from points A, B and C respectively. Carol travels at 56mph, Bettie at 42mph and Ann at 51mph. If they all leave at the same time from work who will get home first?

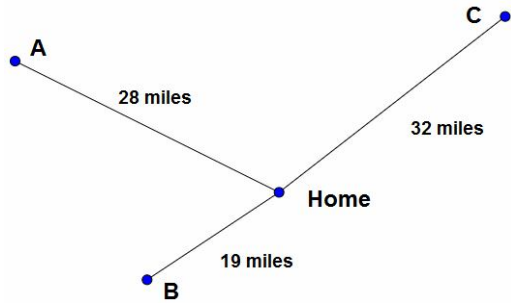

(2) Fred sets up a business making silver dog statues. Each statue needs 248cm^3 of silver. He buys a 1 metre cubic block of silver for £10428 and sells each statue he makes for £16.48. Given that there is no waste in the production process and he sells all of the statues he can possibly make, find the maximum profit Fred can achieve.

(3) In Australia a computer costs \$785 including worldwide shipping. In China the same computer costs 3400 Chinese Yuan including worldwide shipping.

Kate lives in the UK and needs to buy a new computer.

Using the Exchange rates below, advise her on which country to buy it from. You must show full workings.

- 1 Australian dollar = 0.7 US dollars
- 1 US dollar = 0.9 Euro
- 1 Chinese Yuan = 20 Japanese Yen
- 133 Japanese Yen = 1 Euro
- 1 Japanese Yen = 0.5 Indian Rupee

(4) Find the area of the shaded trapezium in the rectangle below.

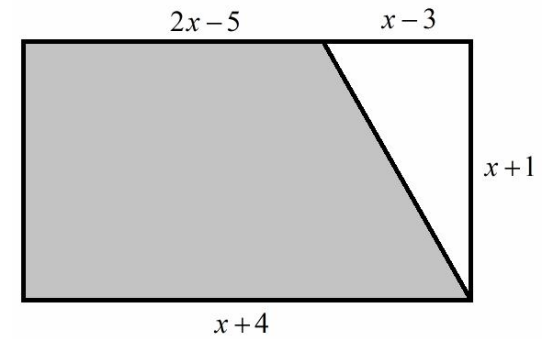

(5) In a bag there are 3 different colour beads. There are red beads, green beads and blue beads. The ratio of red beads to green beads is 2:3. The ratio of blue beads to green beads is 7:15. Given that there are 42 blue beads, find how many more red beads there are than blue beads.

(6) Joel is riding a bicycle. The wheels of the bicycle have a diameter of 78cm including the tyres. Joel rides three and a half kilometres one day. How many complete revolutions will his wheels do on his journey?

(7) John is studying the weather for the next two days. The forecast is either sunny or cloudy. The weather on the second day is not influenced by the weather on the first day. The probability of both days being sunny is 0.28. The probability of the second day being sunny is 0.7. Find the probability that both days are cloudy.

(8) In the diagram below $BC = 8cm$ and is a tangent to the circle. A is the centre of the circle and $AC = 10cm$

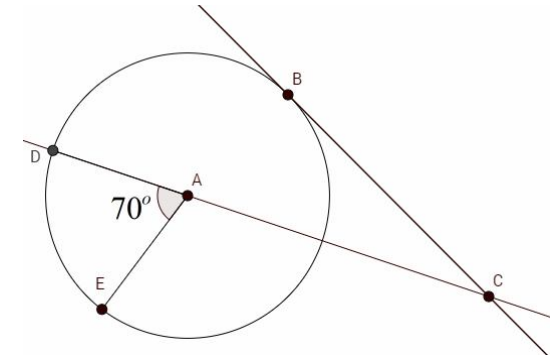

Find the area of the sector ADE giving your answer to 1 decimal place.

Problem Solving GCSE Questions 2

www.m4ths.com

(1) Bob is making cakes. To make 4 cakes he needs 240g of flour, 2 eggs, 360g of sugar and 180g of butter. At home he has half a kilo of flour, half a dozen eggs, 0.3kg of butter and twice as much sugar. What is the maximum number of cakes he can make?

(2) A circular lawn has a diameter of 123.4m. Farmer Fred wants to grow grass seed on the lawn. He can buy boxes of grass seed that cover 1000 square metres of lawn for £3.27 each. Given that he is offered a 15% discount if he purchases more than 10 boxes, find the total cost of grassing the lawn.

(3) Sue draws the square shown below.



Sue then draws the largest circle **inside** the square that she possibly can and colours it in black. Find the area of the square that is still white after she has drawn the circle.

(4) The diagram below shows a right angled triangle.

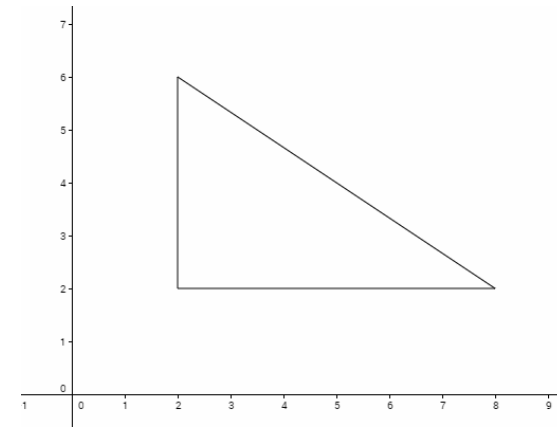

Find the coordinates of the midpoint of the hypotenuse.

(5) Electricals R Us is holding a sale. A Fridge was originally put in a 10% sale and didn't sell. The fridge has been discounted **by a further** 15%. Given that the latest sale price is £417.69, find the **original** price of the fridge before it was discounted twice.

(6) Given that $y = 180 - x$, mark all of the angles below that have a value of y .

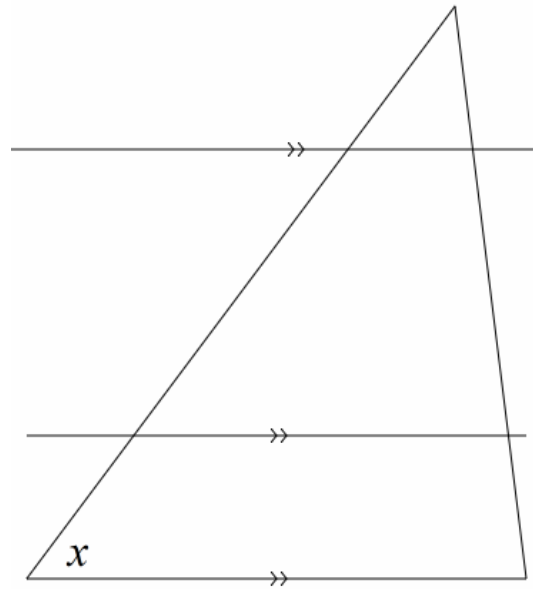

(7) Ken is sending some Christmas Cards. He buys 24 stamps. The stamps are a mixture of 1st and 2nd class. A 1st class stamp is 60p and a 2nd class stamp is 50p. Given that he spends £13 in total on the stamps, find out how many 1st class and how many 2nd class stamps he bought.

(8) Complete the 3 function machines using the 12 options below:

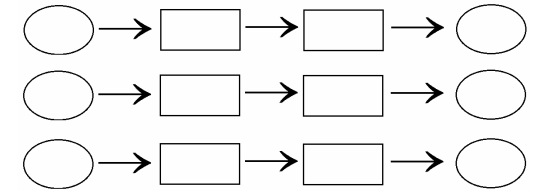

- x
- $2x^2$
- $\times x$
- $x^2 + 3$
- $-x^2$
- $x^2 - 5x$
- $+3$
- x
- $\times 3$
- -4
- $3x - 4$
- -5

Problem Solving GCSE Questions 3

www.m4ths.com

(1) John wants to buy his wife some roses for Valentines Day. They have been together 22 years and John wants to buy 22 roses to celebrate. John has the option of buying the roses from the two companies shown below.

Roses R Us
Roses £1.30 each
10% for orders over £10

Roses.com
£8.80 for a pack of 8 roses

Advise John which company to use if he wants to get 22 roses as cheaply as possible. He can only use one company for his purchase.

(2) In a school the ratio of boys to girls is 1:3.

A number of boys leave the school such that the ratio of boys to girls is now 1:4.

By how much did the percentage of girls increase in the school after the boys left?

(3) Sybil owns a rectangular piece of land as shown in the diagram below.

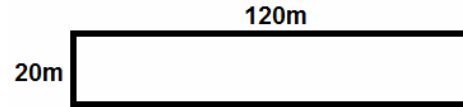

- Sybil needs to section off 400m² for her sheep.
- Sybil needs at least 20% of the total land to grow crops on.
- Of the remaining land Sybil wants to divide it into two equally sized pieces to grow a range of crops.

Using the templates below, show how Sybil can do this. You must show the dimensions of each piece of land clearly.

Practice



Answer



(4) The diagram below shows a square attached to the base of a regular pentagon. The side lengths of the square and the pentagon are equal.

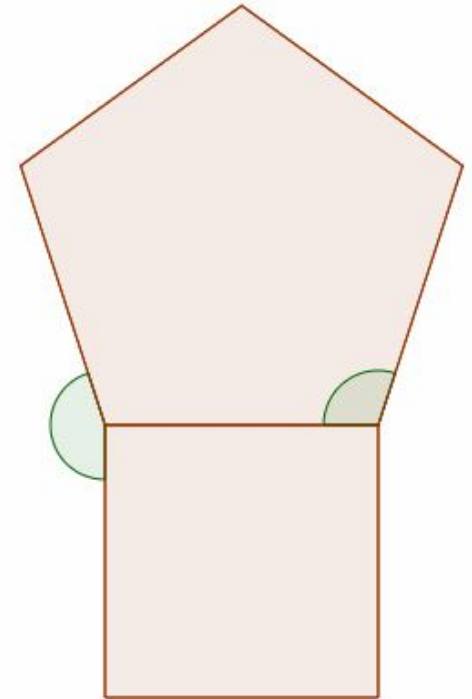

Find the ratio of the size of the larger angle to the size of the smaller angle shown in the diagram. You must give your answer in its simplest form.

(5) Helen is packing Prongles Crisps into the box below. The carton for the crisps is in the shape of a cylinder with a radius of 2.5cm and a height of 4cm.

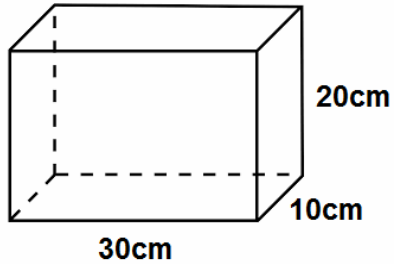

Find the minimum amount of space that is wasted if she puts the maximum number of cartons in the box.

(6) The points $A(3, 8)$, $B(a, 35)$, $C(21, b)$ and $D(c, d)$ all lie on the same straight line. Given that $AB = BC = CD$, find the values of a, b, c and d .

(7) Below are two tables showing some information about the scores obtained by boys and girls sitting the same exam. The exam was out of 100.

Lowest Score	12
Lower Quartile	20
Median	48
Upper Quartile	
Highest Score	

Lowest Score	
Lower Quartile	25
Median	
Upper Quartile	48
Highest Score	64

Here are some facts about the results:

1. The Boys IQR was double the girls
2. The difference between the medians was 6.
3. The highest scoring boy scored 7 times more than the lowest scoring boy.
4. The range of the girls scores was two thirds of the range of the boys scores.

Using this information, complete the two tables.

(8) Given that the perimeter of the rectangle below is 26 units, find the area of the square shown below.

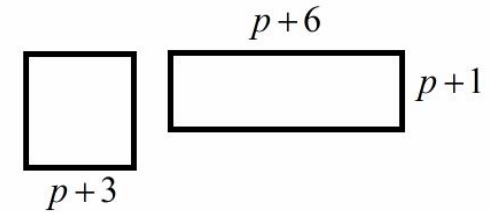

Problem Solving GCSE Questions 4

www.m4ths.com

(1) A and B are both integers.
The highest common factor of A and B is 2.
96 is a multiple of both A and B .
 $A \div B$ is a non-integer.
 $B \div A$ is a non-integer.
Find possible values for A and B .

(2) In a school the ratio of boys to girls in year 7 is 5:6.

In year 7 the ratio of boys preferring rugby to the boys preferring football is 4:11.

Given that there 198 pupils in year 7, find out how many boys in year 7 preferred football to rugby.

(3) A tank is two thirds full and currently holds 40lt of water.
The tank is emptied completely before being filled at the rate of 200ml per minute.

How long will the tank take to fill completely from empty?
You must give your answer in hours.

(4) The cuboid shown below is made of solid gold.

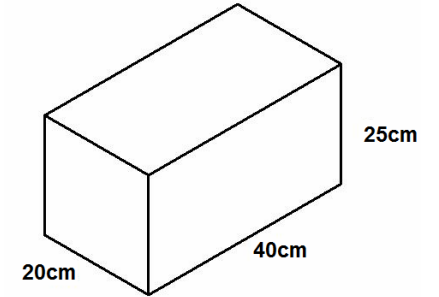

The gold will be melted down to make solid right triangular gold wedges as shown below.

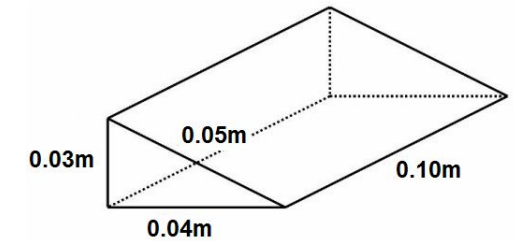

What is the maximum number of gold wedges that can be made from the cuboid?

(You can assume there will be no wastage in the process of making the wedges).

(5) Find the area of the rectangle below.

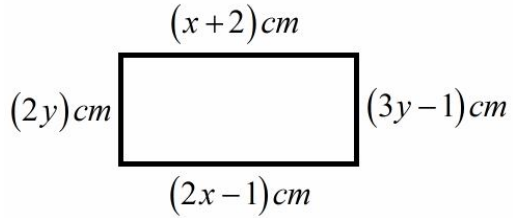

You must give your answer in m^2 .

(6) Sergio is playing on the computer. He plays two different games, Game 1 and Game 2.

The two events are independent. The tree diagram shows some of the information below.

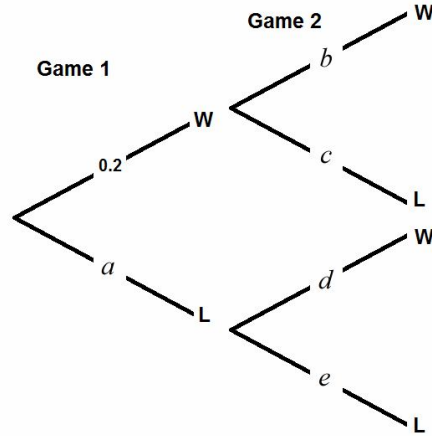

Given that the probability of Sergio losing both games is $12/25$, find the values of a, b, c, d and e .

(7) $ABCD$ is a quadrilateral.

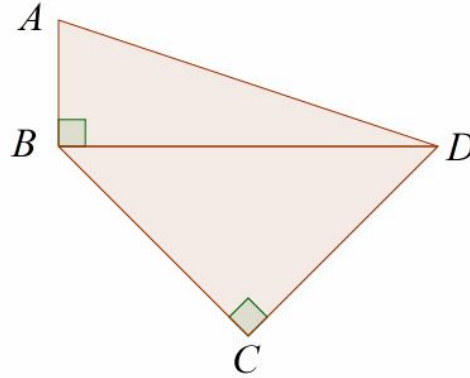

BCD is a right angled isosceles triangle.

$$CD = 5cm$$

$$AD = 8cm$$

Find the area of $ABCD$ giving your answer to one decimal place.

(8) Bob has 3 different spinners. Each spinner has 4 different numbers on it. He spins each spinner once and records the number obtained. Find the probability that all 3 numbers obtained are prime numbers.

Spinner 1

Number	1	2	10	11
Probability	$2x$	$4x$	$3x$	x

Spinner 2

Number	5	6	18	19
Probability	y	y	0.7	$4y$

Spinner 3

Number	3	4	8	9
Probability	z	z	z	z

Problem Solving GCSE Questions 5

www.m4ths.com

(1) Bob buys 40 plants for £72. One fifth of the plants have to be thrown away immediately due to them being in a poor state. Bob splits the remaining plants into large plants and small plants. The ratio of large plants to small plants is 1:3. He sells the large plants for £4 and the small plants for £2. Will Bob make a profit if he sells all of the remaining plants? If so, how much?

(2) Town A is on a bearing of 290° from Town B. The distance from Town A to Town B is 12 miles.
(a) Find the bearing of Town B from Town A.
Freda cycles from Town B to Town A. She leaves at 10:32am and arrives at 11:17am without taking a break.
(b) Find her average speed in miles per hour for the journey from Town B to Town A.

(3) Ranjita is making metal pendants. She has designed the pendant such that it's in the shape of a rectangle with a triangle on the top. The pendant will have a thickness of 5mm. The design is shown below.

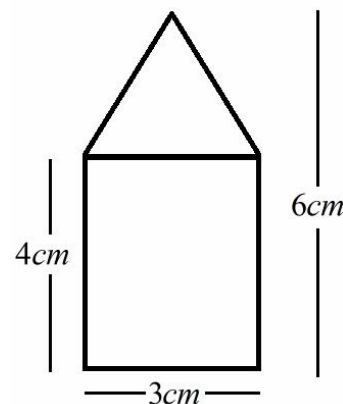

The price of the metal she is using is £2.50 for 1cm^3 . Find the cost of making 4 pendants.
You may assume there is no waste in the production process.

(4) Kelly and Kevin are both sitting the same exam at school. The exam consists of 5 papers. Each paper is out of 100 marks. Kevin has bet Kelly that his average score will be at least 10 marks per paper higher than hers. The table below shows the scores for the first 4 papers for Kelly and Kevin.

	Paper 1	Paper 2	Paper 3	Paper 4
Kelly	48	53	73	54
Kevin	82	86	91	67

Kevin doesn't know what score Kelly scored in the 5th paper before he sits his 5th paper. What is the minimum score Kevin must get in the 5th paper to ensure he wins the bet?

(5) In a factory the ratio of men to woman is 2:3
 The ratio of right handed men to left handed men is 7:3.
 The ratio of right handed women to left handed women is 11:1
 What proportion of the people working in the factory are right handed?

(6) The two Russian Dolls shown below are mathematically similar.



Janet wants to paint the smaller of the Russian Dolls.
 She knows the larger doll costs £2.56 to paint. Find the cost of painting the smaller doll.

(7) The diagram below shows part of a circle with centre O .

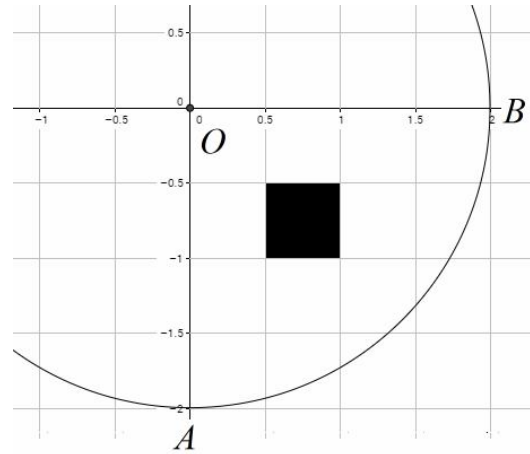

The sector AOB has a black square in.
 Find what percentage of the sector AOB is taken up by the black square giving your answer to two decimal places.

(8) Part of a regular polygon is shown below.

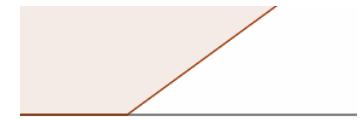

The exterior angle of the polygon shown is $(7x+1)^\circ$.

The interior angle shown is $(28x+4)^\circ$.
 Name the polygon clearly showing how you found your answer.

Problem Solving GCSE Questions 6
(Christmas Edition!)

www.m4ths.com

(1) Jane wakes up on Christmas Eve. She looks at her clock and it reads 05:18.

Given that the clock is 21 minutes fast, how long will it be until it is Christmas Day?

Give your answer in hours and minutes.

(2) The diagram below shows the rectangles $ABCD$ and $EFGH$. The points A, E, B and F lie on a straight line.

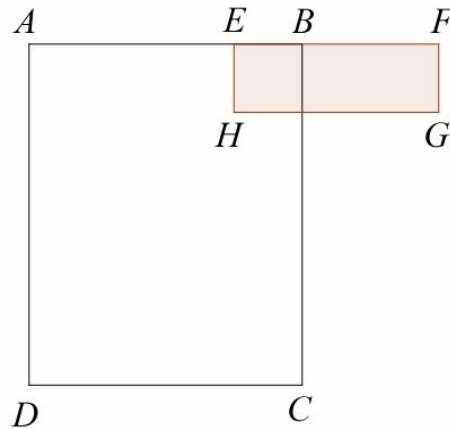

- $CD = 4cm$
- $AD = 5cm$
- $AB = 4EB$
- $BC = 5EH$
- $BF = 2EB$

Find the area of rectangle $EFGH$.
 You must show clearly your working.

(3) Kate is making a Christmas cake. The ratio of flour to sugar to treacle to almonds to butter is 4:3:2:1:1. The weight of the cake is reduced by 10% after it's baked. Given that Kate uses 150g of treacle in the mix, find the weight of the cake after it is baked.

(4) A snow man is made of two perfectly spherical balls of snow. The sphere used for the head is half the size of the sphere used for the body.

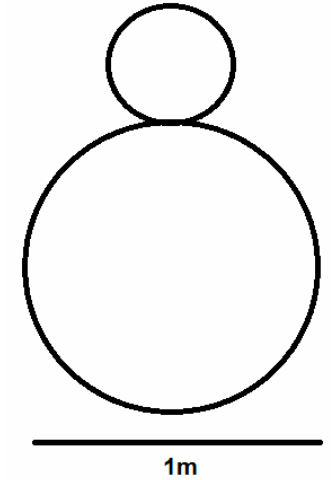

Complete the following sentence
 'The head of the makes up one _____ of the total volume of the snowman'

The volume of a sphere is $V = \frac{4}{3}\pi r^3$

(5) Santa is riding on his sleigh. He has 500 miles to travel to deliver all the presents he needs to. He can average 30mph on his sleigh when he is delivering the presents. Santa leaves his grotto at midnight. Given that the number of miles travelled is correct to the nearest 10 miles and his speed correct to the nearest 1mph, show that he can't guarantee that he will arrive back at his grotto by 5pm.

(6) Below is a picture of a large Christmas tree.

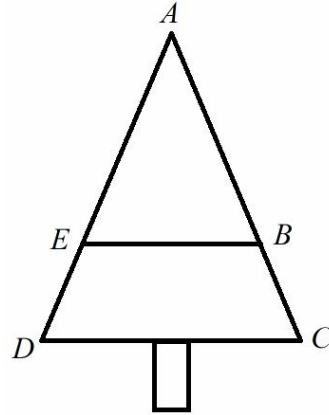

EB and DC are parallel.

$$AB = 6m$$

$$BC = 3m$$

$$EB = 4.5m$$

Find:

- (a) The length DC
- (b) The height of the tree given that the trunk is 2m long.

(7) A 1m cube of gold is melted down in 100 equal sized cubes. Find the dimensions of one of the 100 cubes. You must give your answer in cm correct to 3 significant figures.

(8) Below is a circle with centre O . The line $AB = 9cm$ and is a tangent to the circle. Given that angle $OAB = 20^\circ$, find the area of the shaded sector.

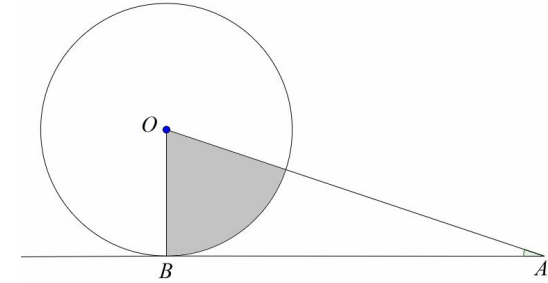

Problem Solving GCSE Questions 7

www.m4ths.com

(1) a, b and c are integers.

$$-4 < a \leq 1$$

$$-6.7 < b \leq 5$$

$$-5 \leq c < -2.8$$

Find the greatest and least value of abc .

(2) The trapezium $ADCDE$ is shown below.

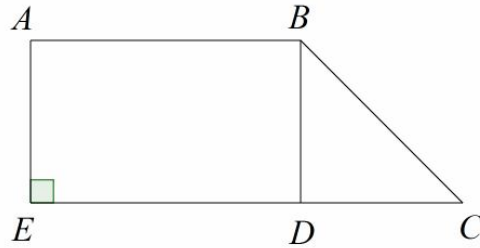

EDC is a straight line.

BD is perpendicular to EDC

$$AB = 5.5\text{cm}$$

$$DC = 3.1\text{cm}$$

$$\text{Angle } BCD = 47^\circ$$

Find the perimeter of the trapezium.

Give your answer to 2 decimal places.

(3) Fred, John and Kathy share some money in the ratio 3:2:7.

Kathy has £600 more than John.

Fred invests his share in a bank account paying 5% compound interest a year.

How much will Fred's investment be worth after 8 years?

Give your answer to the nearest penny.

(4) Bo has a pond with a path around it. The pond is a circle with radius 2.5m. The path is also circular in shape has a constant width of 1.2m.

A diagram of the pond is shown below. The grey shaded area represents the pond and the white area represents the path.

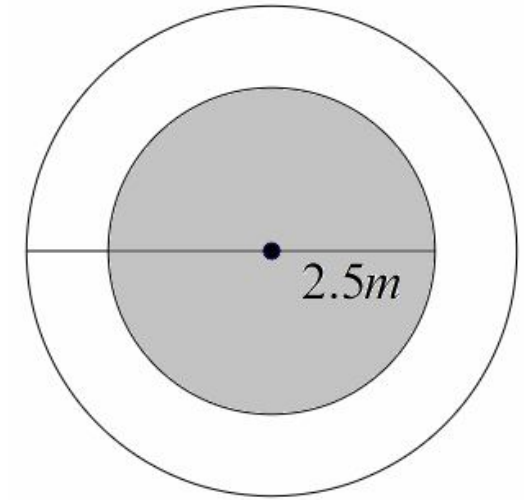

Bo wants to lay grass seed on the path. He can buy grass seed for £4.60 a box and each box covers 5 square metres. Find the cost of buying enough grass seed to cover the path.

(5) John and Jane are twins.
They are both in the same class at school with 11 other children.

The mean height of the class is 156cm.

The mean height of the class without John is 155.5cm.

The mean height of the class without Jane is 157.1cm.

Find the difference in height between John and Jane.

Give your answer in metres.

(6) A plane flies east from an airport for 120km.

The plane then turns and flies on a bearing of 330° until it's directly north of the airport.

How far from the airport is the plane when it's directly north of the airport?

Give your answer to the nearest 1 km.

(7) The diagram below shows the rectangle $ABCD$.

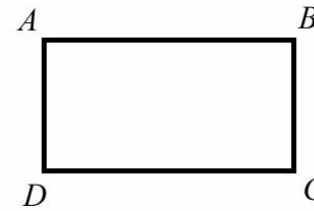

$$AB = 12\text{cm}$$

$$BC = 7\text{cm}$$

Both AB and BC are measured correct to the nearest 1cm.

Find:

(a) The maximum area of the rectangle.

(b) The minimum perimeter of the rectangle.

(c) The maximum length of AC .

Give your answers to 2 decimal places where appropriate.

(8) Given that

$$(x+a)(x+b) = x^2 - x - 6$$

and $a > b$, find the value of $4a - 5b$.

Problem Solving GCSE Questions 8
www.m4ths.com

(1) The diagram below shows a triangle with a square inside.

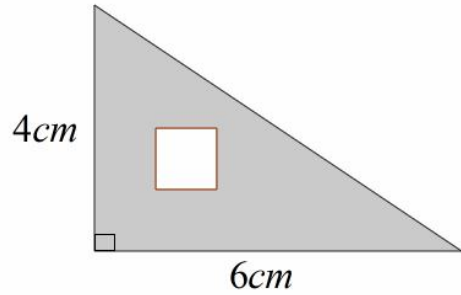

Given that the area of the square is one twelfth the area of the triangle, find the perimeter of the square.

(2) Given that a and b are integers and:

$$\frac{2}{3} + \frac{a}{b} + \frac{1}{12} = \frac{9}{4}$$

Without a calculator, find the least value of a^b .

(3) Janet saves some money in an account at her bank. They offer her two different plans.

Plan 1
5% Compound interest each year.

Plan 2
6% Simple interest each year.

Janet decides to invest £520 for 7 years. Advise Janet on which plan she should take. You must show clear workings.

(4) The diagram below shows a regular octagon with a right angled triangle attached to it.

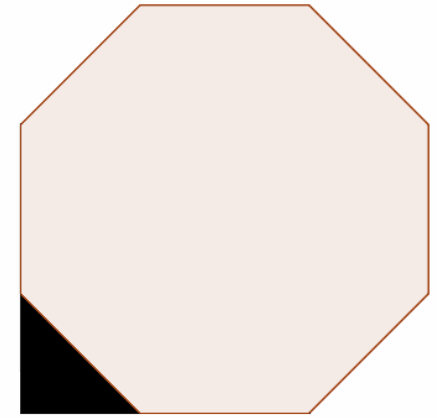

Given that the perimeter of the octagon is 56cm, find the area of the triangle.

(5) The diagram below shows a triangle with a semicircle attached to the bottom.

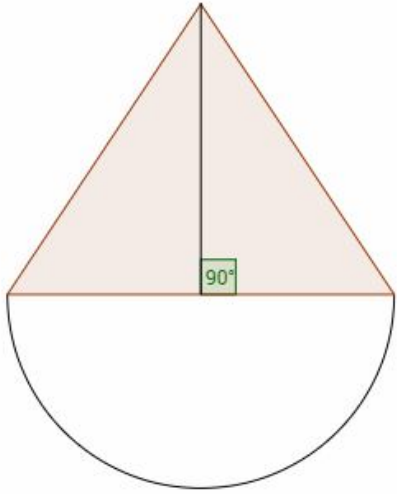

Given that the area of the triangle is 6cm^2 and it has a height of 3cm , find the perimeter of the semicircle. Give your answer correct to 2 decimal places.

(6) The table below shows the distances (in miles) between a number of different towns.

	A	B	C	D	E	F
A	-	10	13	12	15	20
B	10	-	8	7	11	5
C	13	8	-	6	9	14
D	12	7	6	-	18	2
E	15	11	9	18	-	3
F	20	5	14	2	3	-

Bob drives from Town A to Town E via Town D. He spends a total of 45 minutes driving to complete the journey.

Jane travels directly between two of the towns at exactly the same average speed as Bob. Given that Jane's journey took seven and a half minutes, find which two towns she drove between.

(7) a, b and c are the only three values of a data set where $a < b < c$. The data set has a range of 12 and the median value is 4. Given that $b - a = c - b$, find the values of a, b and c .

(8) Farmer Fred has 320 sheep pens. The first 4 sheep pens are shown below.

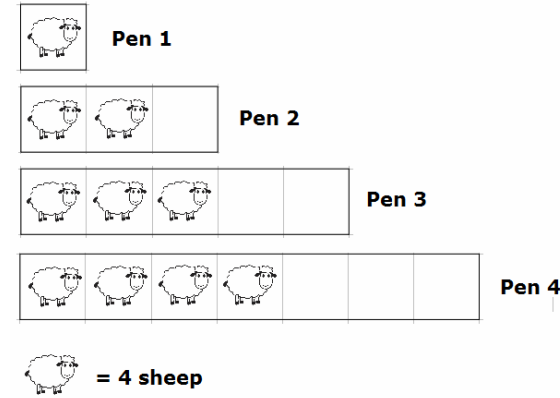

Pen 1 has 1 square metre of land and has 4 sheep in it.
 Pen 2 has 3 square metres of land and has 8 sheep in it.
 This pattern continues up until the 320th pen.
 The area of the 320th pen is divided equally between the sheep in the pen. How much space does each sheep in the 320th pen have?
 Give your answer to 3 significant figures.

Problem Solving GCSE Questions 9

www.m4ths.com

(1) Two cars are for sale at a garage.

Car 1
£22500 including
VAT at 20%

Car 2
£19888 excluding
VAT at 20%

Find the difference between the pre VAT prices of the two cars.

(2) Fred travels on a bearing of 048° for 5 miles. How far east has Fred travelled from his original starting point?

(3) An isosceles triangle is shown in the diagram below.

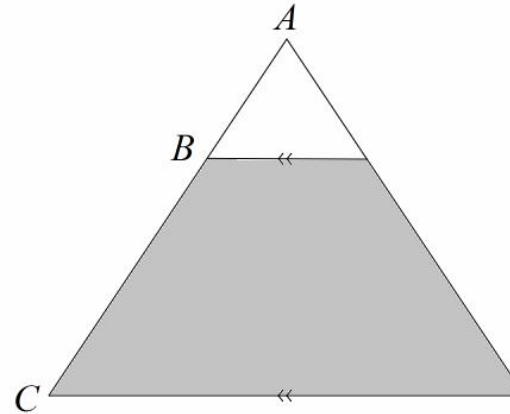

The ratio of $AB : BC$ is $1 : 2$.
What fraction of the triangle is not shaded?

(4) Jane can travel 475 miles on 38 litres of petrol. Jane is going on a road trip. Jane leaves home at 4:15pm and arrives at her destination at 7:35pm. Given that she travels at an average speed of 42mph, find the amount of petrol she uses.

(5) A circle with radius 5cm is shown in the diagram below. The circle has a square drawn inside. The vertices of the square lie on the circumference of the circle.

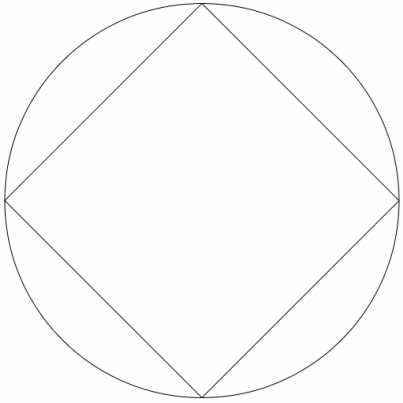

Find the perimeter of the square.
Give your answer to one decimal place.

(6) The diagram below shows a rectangle. Using the information given in the diagram, find the value of $x^2 - 2y$.

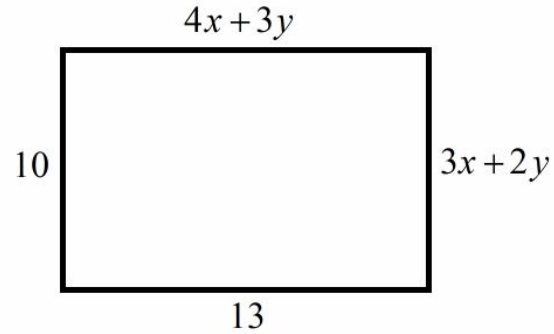

(7) In a factory the ratio of men to women is 1:4. 15% of the men in the factory leave. What percentage of the total number of people left in the factory are women?

(8) There are 8 counters in a box. Half are red and half are not. 3 counters are taken out and not replaced. Find the probability that at most 2 counters chosen are red.

Problem Solving GCSE Questions 10

www.m4ths.com

(1) Sam scored 37 out of 53 in a test.
Jim scored 67 out of 96 in a test.
Who had the highest proportion of correct answers?

(2) The diagram below shows the quadrilateral $ABCD$.

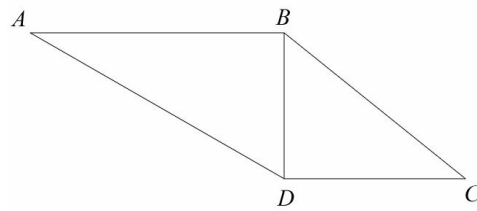

$$AB = 7$$

$$BC = \sqrt{41}$$

$$CD = 5$$

BD is perpendicular to AB and DC .

Find the size of Angle BAD .

(3) It takes 8 men 16 days to build a wall.

4 men work at the same rate and get paid £120 for each day they work.
Find the total cost of hiring the 4 men to complete the job.

(4) The diagram below shows two similar trapeziums.

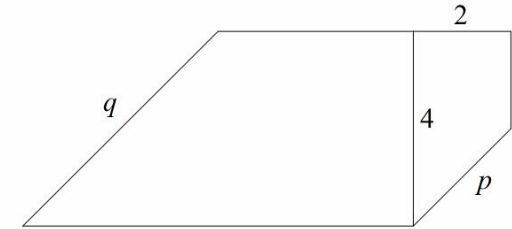

Express p in terms of q .

(5) Complete the table below.

Age	Frequency	Cumulative Frequency	Frequency Density
0-10	6		
		14	
20-30		20	
			2
50-60	8		

(6) The triangle in the diagram below has side lengths $2x$, $(x+2)$ and $(x+1)$.

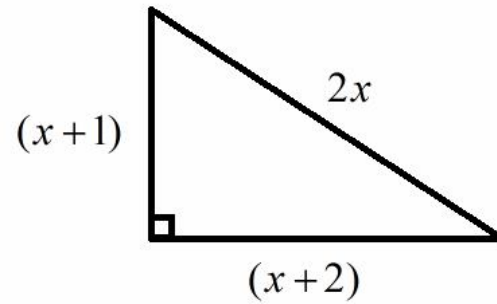

Show that $2x^2 - 6x - 5 = 0$.

(7) Find the area of a circle with a circumference of $8\pi cm$,
Give your answer in terms of π .

(8) The bearing of Town B from Town A is $(2x-10)^\circ$.

The bearing of Town A from Town B is $(7x-30)^\circ$.

Find the value of x .

Problem Solving GCSE Questions 11
www.m4ths.com

(1) Rock 1 has a mass of 320g and a volume of 512cm^3 . Rock 2 has two thirds of the mass of Rock 1 yet has twice its volume. Find the difference in the density of the two rocks. Give your answer to 3 significant figures

(2) A square metre has two of its side lengths decreased by 1cm and two of its side lengths increased by 3cm to make a rectangle. Find the percentage change in the area of the shape after the alterations.

(3) Sue has £5000 to invest and wants to put the money into a savings account for 4 years. Sue has the following 3 options:

Option 1

Simple interest paid at 5% per annum.

Option 2

Compound interest paid at 4.5% per annum.

Option 3

A lump sum of 9% of the original investment paid at the end of the 4 years.

Advise Sue on which option she should take if she wants the greatest amount of money at the end of the 4 years.

(4) Show that the area of the triangle below can be written in the form $ax^2 - b$.

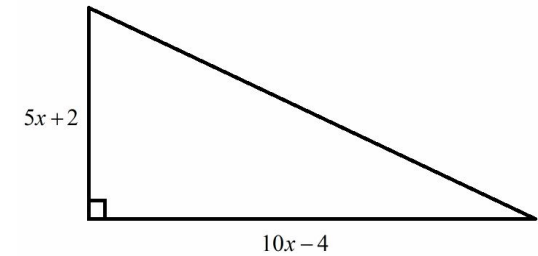

(5) The diagram below shows an isosceles triangle and a circle.

The hypotenuse of the triangle passes through the centre of the circle.

The two shorter sides of the triangle are tangents to the circle

The area of the isosceles triangle is $50u^2$.

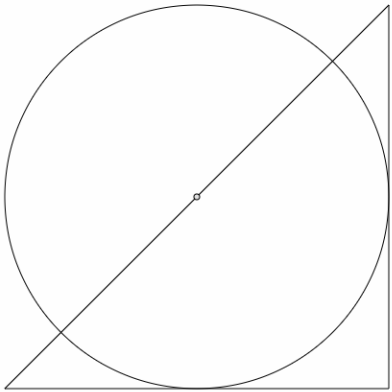

Find the circumference of the circle.

(6) The 3 spinners below are each spun once and the number written down.

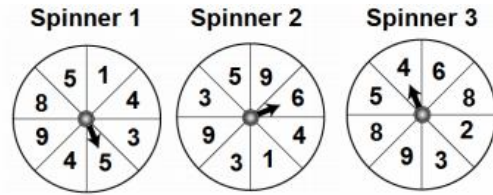

Find the probability that when the three spinners are spun the numbers are either all prime numbers **or** all cube numbers.

(7) An equilateral triangle has a perimeter of 12cm. find the area of the triangle.

(8) Fred travels on a bearing of 120° for 8km. Fred then travels north for 4km. Show that he is directly east of his starting point.

Problem Solving GCSE Questions 12
www.m4ths.com

(1) In an office there are 100 people in total.

$\frac{1}{4}$ of the people in the office bike to work.

The ratio of men biking to women biking to work is 3:2

The number of women coming by bus is twice the number of women who come by bike.

35 people walk and of those 12 are men.

Find the number of men who catch the bus to work.

(2) A stopwatch loses time at the rate of 1 second every 10 seconds. Bob reads the stopwatch and it says 2 minutes and 6 seconds. How much time has actually passed?

(3) Find the value of p and the value of q in the diagram below.

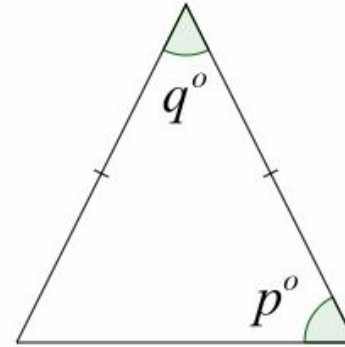

(4) (a) Find an expression for the volume of the cuboid below in terms of x .

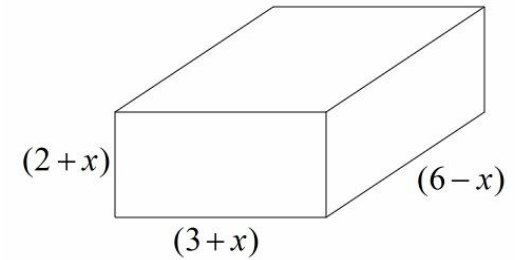

(b) Find the difference in the surface area of the box when $x = 2$ and when $x = 4$.

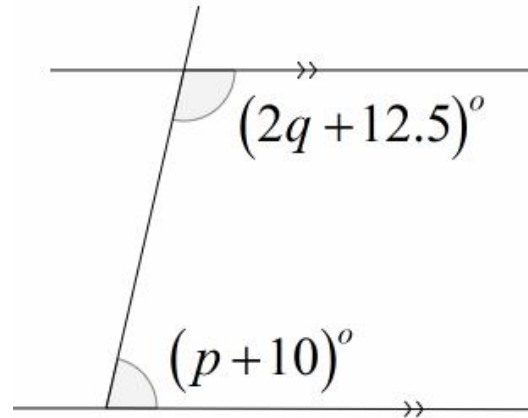

(5) The area of the sector below is $24\pi\text{cm}^2$.

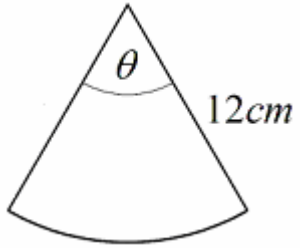

Find the perimeter of the sector.

(6) The 3 spinners below are each spun once and the number written down.

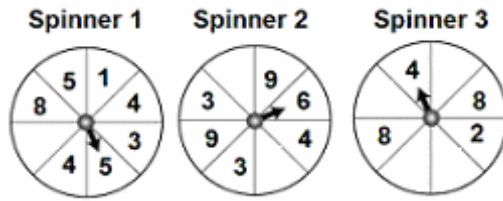

The probability of spinning a prime number on each of the spinners is given as:

$$\frac{1}{2} \times \frac{1}{2^2} \times \frac{1}{2^3} = \frac{1}{2^6}$$

Complete the missing sections on the spinners to make this calculation true.

(7) Find the area of the triangle below.

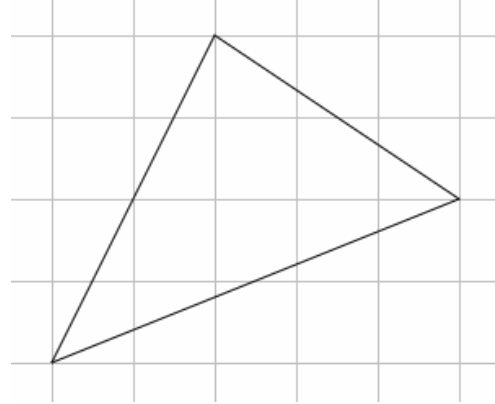

(8) Triangle ACD and triangle ABE are mathematically similar.

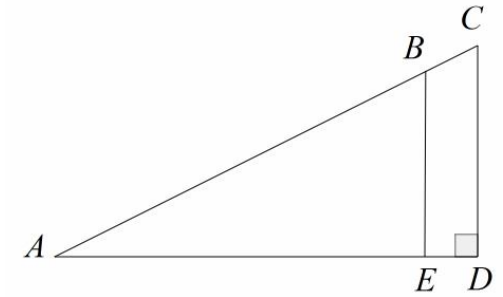

Angle $CAD = 32^\circ$

$AC = 9\text{cm}$

$6BE = 5CD$

Find the length of AE giving your answer to 3 significant figures.

Problem Solving GCSE Questions 13

www.m4ths.com

(1) The cost per person to pay for their seat on a minibus is inversely proportion to the number of people who pay for a seat.

When 10 people pay, the cost is £32 per person.

Find the cost per person when 16 people pay.

(2) Fred is 1.23m tall

Jim is 135cm tall.

Fred is increasing in height at a rate of 3% a year.

Jim is shrinking at a rate of 2% a year.

Find the difference in the height of Fred and the height of Jim in 7 years time.

(3) The area of the circle below is $16\pi \text{ cm}^2$.

The smallest angle in the triangle is 30° .

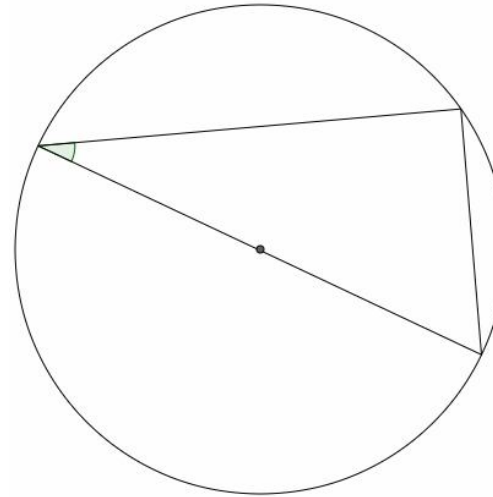

Find the area of the triangle. Give your answer to 3 significant figures.

(4) Find the perimeter of the shaded trapezium in the rectangle below.

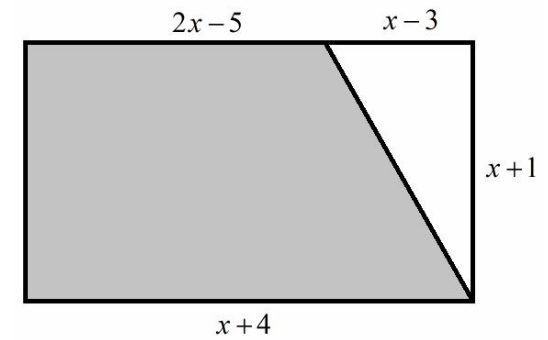

(5) In a bag there are 3 different colour beads. There are red beads, green beads and blue beads. The ratio of red beads to green beads is 2:3. The ratio of blue beads to green beads is 7:15. Given that there are 42 blue beads, find how many more red beads there are than blue beads.

(6) A closed top cuboid is shown in the diagram below.

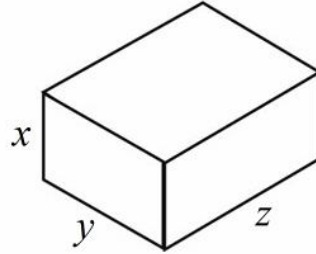

- (a) Find an expression for the volume of the cuboid in terms of x , y and z .
- (b) Find an expression for the surface area of the cuboid in terms of x , y and z .
- (c) Given that an expression for the density of the cuboid is y^2 , find a simplified expression for the mass of the cuboid.

(7) Fred looks at the weather forecast for the next two days. The forecast is either sunny or cloudy. The probability of it being sunny on either day is the same. The probability of both days being sunny is 0.36. Find the probability that only one of the days is sunny.

(8) Without using a calculator, put the following values in ascending order. You must show your workings.

$$\left(\frac{25}{64}\right)^{\frac{1}{2}} \quad 2^{-2} \quad 8^{\frac{1}{3}} \quad \frac{5}{16}$$

Problem Solving GCSE Questions 14
www.m4ths.com

(1) Show that $\frac{17}{32}$ of the square below is shaded.

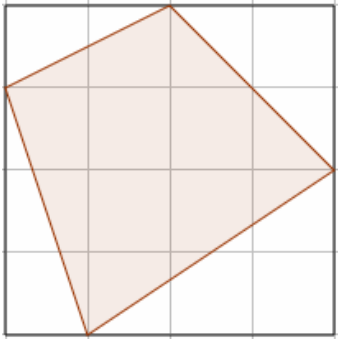

(2) Fred wants to drive from Town A to Town C via Town B.

Town A to Town B is 12 miles.
Town B to Town C is 16 miles.

Fred leaves Town A at 10:20 and arrives at Town B at 11:00.

If Fred drives twice as fast as he did on the first part of his journey, what is the latest time he can leave Town B to get to Town C for 1pm?

(3) The diagram below shows a cumulative frequency curve and some information about heights of plants in a survey.

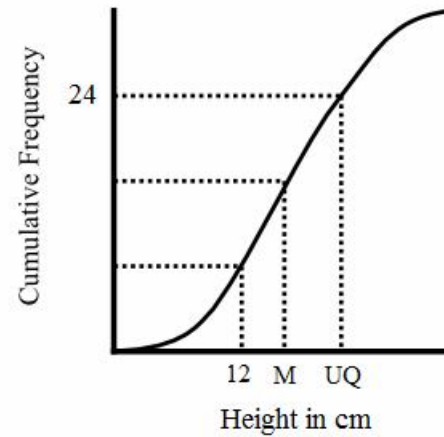

Find an estimate for the number of plants with a height of 12cm or more.

(4) The diagram below shows a quadrilateral drawn inside a rectangle.

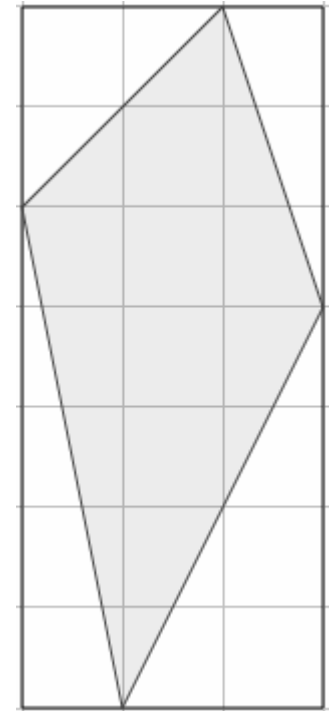

Find the size of the smallest interior angle of the quadrilateral. Give your answer to 3 significant figures.

(5) The larger cylinder shown below holds 7 smaller identical solid cylinders inside. All 8 of the cylinders shown have the same height.

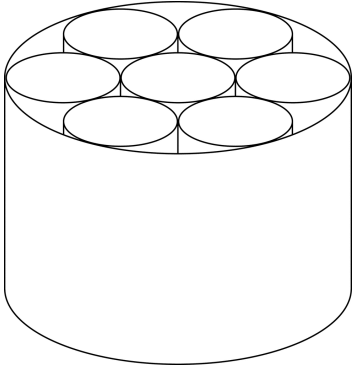

Given that the radius of each smaller cylinder is rcm , show that seven ninths of the capacity of the larger cylinder is occupied by the smaller cylinders.

(6) Given that:

$$\frac{2}{3} \div \frac{a}{b} = \frac{5}{6} \quad \text{and} \quad b + 5a = 29$$

find the value of a and the value of b .
You must show your workings.

(7) Without using a calculator, find the next cube number after 9261.

(8) The diagram below shows a quadrilateral drawn inside a circle. The points A, B, C and D lie on the circumference of the circle.

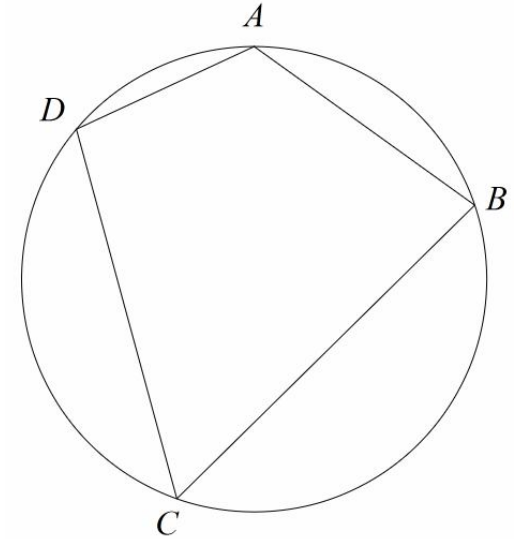

$$\text{Angle } ABC = 16x + y$$

$$\text{Angle } BCD = 84^\circ$$

$$\text{Angle } CDA = 94^\circ$$

$$\text{Angle } DAB = 20x + y$$

Find the value of x and the value of y .

Problem Solving GCSE Questions 15

www.m4ths.com

(1) The diagram below shows a right angled triangle.

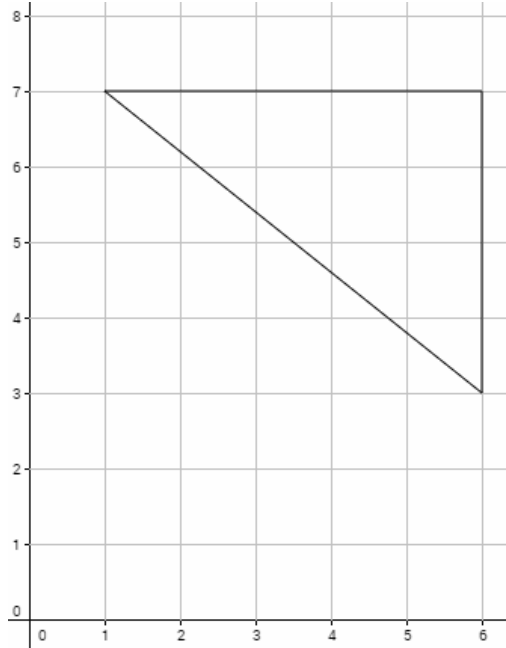

Rectangle *A* is the largest rectangle that can be drawn inside the triangle with an integer value for its area.

Find the perimeter of rectangle *A*.

(2) The diagram below shows art for the curve with equation $y = -f(x)$.

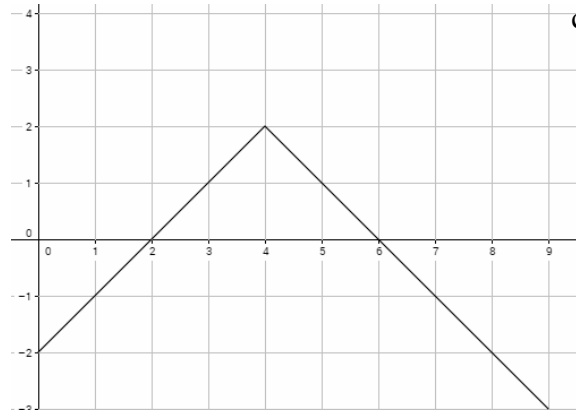

Sketch the graph of $y = f(2x)$ below.

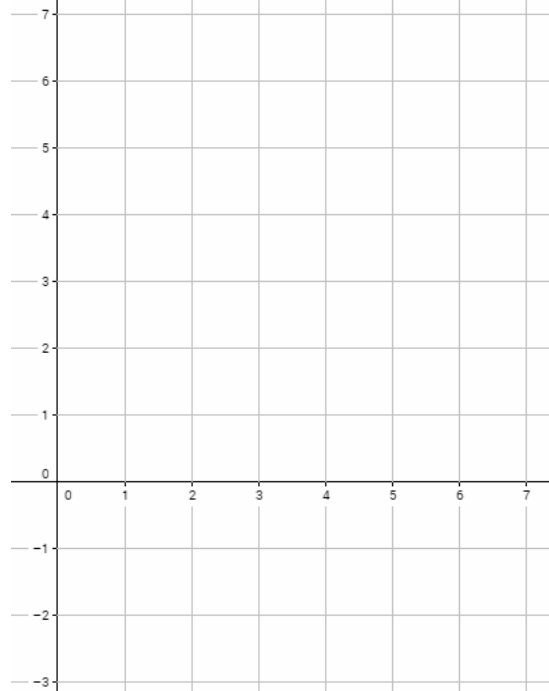

(3) The diagram below shows two circles. The ratio of the radius of the smaller circle to that of the larger circle is 2:5.

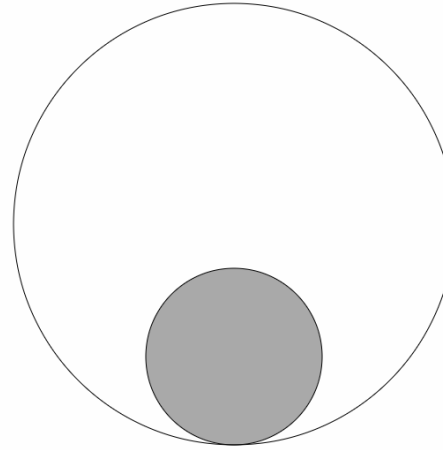

Without using a calculator find the shaded percentage of the larger circle?

(4) The triangle in Question (1) has had two side lengths increased in length as shown below.

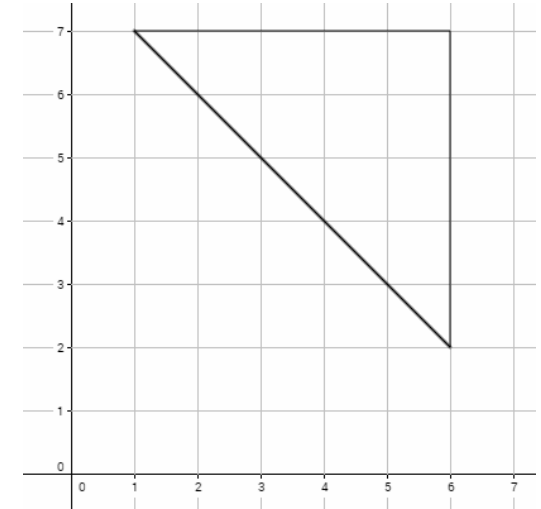

Rectangle *B* is the largest rectangle that can be drawn inside the triangle.

Without using a calculator, find the perimeter of rectangle *B*.

(5) A square has an area of 12cm^2 . Without using a calculator, find the perimeter of the square in the form $a\sqrt{b}$.

(6) The clock shown below has two hands, the hour hand and the minute hand.

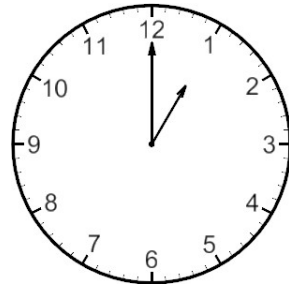

The hour hand is 5cm long.
The hour hand is one half the length of the minute hand.

Find distance between the tips of each hand when the time is 15:00 hrs.

(7) (a) Without using a calculator, show that $0.\dot{4}$ can be written as a simplified fraction in the form $\frac{a}{b}$.

(b) Using your answer found in part (a), express $0.\dot{a}\dot{b}$ as a fraction in its simplest form.

(8) Without using a calculator, find the next term in the following sequence and state the term to term rule for the sequence:

$$\sqrt{2}, 1, \frac{\sqrt{2}}{2}, \frac{1}{2}, \frac{\sqrt{2}}{4}, \dots$$

Answers (Please check them as they are from students marked work!)

Questions 1

- (1) Bettie in just over 27 minutes
- (2) £56019.36
- (3) Australia (about €16-17 cheaper)
- (4) $59.5u^2$
- (5) 18
- (6) Each wheel will do 1428
- (7) 22.0cm^2

Questions 2

- (1) 6
- (2) ~£33.35
- (3) 17.4cm^2
- (4) (5, 4)
- (5) £546
- (6)

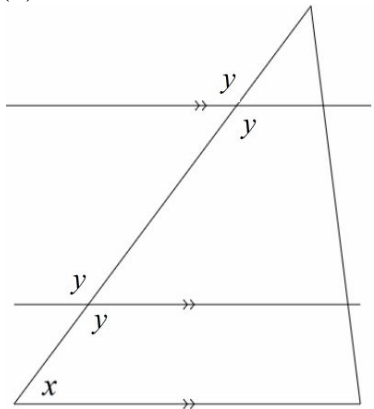

- (7) 10 1st and 14 2nd class stamps.
- (8) In any order

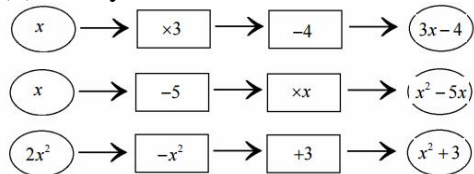

Questions 3

- (1) Roses R Us by 66p
- (2) 5%
- (3) One of many below!

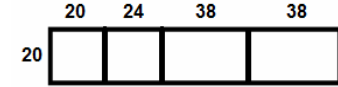

- (4) 3:2
- (5) 1287.6cm^3
- (6)
- $a = 12$
- $b = 52$
- $c = 30$
- $d = 79$
- (7)

Boys

Lowest Score	12
Lower Quartile	20
Median	48
Upper Quartile	63
Highest Score	84

Girls

Lowest Score	16
Lower Quartile	25
Median	42
Upper Quartile	48
Highest Score	64

- (8) 36cm^2

Questions 4

- (1) Loads! 4 and 6, 6 and 8 etc etc
- (2) 42
- (3) 5 hours
- (4) 333
- (5) 0.001m^2

- (6)
- $a = 0.8$
- $b = 0.4$
- $c = 0.6$
- $d = 0.4$
- $e = 0.6$
- (7) 25.7cm^2
- (8) 0.0125 or $\frac{1}{80}$

Questions 5

- (1) Yes, £8
- (2) (a) 110° (b) 16mph
- (3) £75
- (4) 52
- (5) 83%
- (6) £1.44
- (7) 7.96%
- (8) Decagon

Questions 6

- (1) 19 hours and 3 minutes.
- (2) 3cm^2
- (3) 742.5g
- (4) Ninth
- (5) $\frac{505}{29.5} = 17$ hours and 7 minutes.

This gives ~5.07pm
(Use of upper and lower bounds).

- (6) (a) 6.75m (b) 10.34m
- (7) 21.5cm
- (8) 6.55cm^2

Questions 7

- (1) 0 and -90

- (2) 21.97cm
- (3) £531.88
- (4) £23
- (5) 0.192m
- (6) 208km
- (7)
- $a = 93.75\text{cm}^2$
- $b = 36\text{cm}$
- $c = 14.58\text{cm}$
- (8) 23

Questions 8

- (1) 4cm
- (2) 9
- (3) Plan 2. It's ~£6.71 more.
- (4) 12.25cm^2
- (5) 10.28cm
- (6) B and F (or F and B)
- (7)
- $a = -2$
- $b = 4$
- $c = 10$
- (8) 0.499m^2

Questions 9

- (1) £1138
- (2) 3.72 miles (2 dp)
- (3) $1/9^{\text{th}}$
- (4) 11.2 litres
- (5) 35.4cm
- (6) 18
- (7) 83%
- (8) 13/14

Questions 10

- (1) Sam (Just!)
- (2) 29.7°

(3) £3840

(4) $p = \frac{1}{2}q$

(5)

Age	Frequency	Cumulative Frequency	Frequency Density
0-10	6	6	0.6
10-20	8	14	0.8
20-30	6	20	0.6
30-50	40	60	2
50-60	8	68	0.8

(6) Use of Pythagoras theorem

(7) $16\pi \text{ cm}^2$

(8) 40°

Questions 11

(1) $0.412 \text{ gm} / \text{cm}^3$

(2) 1.97% increase

(3) 1st option

(4) $\frac{1}{2}(10x-4)(5x+2) = 25x^2 - 4$

(5) 31.4cm

(6) $1/16$ or $32/512$ or 0.0625

(7) 6.93 cm^2 or $4\sqrt{3} \text{ cm}^2$

(8) $8\sin(30^\circ) = 4$ (Triangle drawn) could be one way!

Questions 12

(1) 20

(2) 140seconds (2 mins 20)

(3) $p = 67.5^\circ$ and $q = 45^\circ$

(4) (a) $(2+x)(3+x)(6-x)$ accept expanded version.

(b) 24 cm^2

(5) 36.6cm (3 sf)

(6)

1st Any prime

2nd Any two non prime

3rd Any three non prime

(7) $8u^2$

(8) 6.36cm

Questions 13

(1) £20

(2) 34.1cm (1 dp)

(3) 13.9 cm^2 (1 dp)

(4) 31.6cm (1 dp)

(5) 18

(6)

(a) xyz

(b) $2(xy + xz + yz)$

(c) xy^3z

(7) 0.48

(8) $2^{-2}, \frac{5}{16}, 8^{-\frac{1}{3}}, \left(\frac{25}{64}\right)^{\frac{1}{2}}$

Questions 14

(1) $16 - 1 - 2 - 3 - \frac{3}{2} = \frac{17}{2}$

(Area of square - 4 triangles)

(2) 12:30pm

(3) 24

(4) 37.9° (3 SF)

(5) Small cylinders = $7 \times \pi r^2$

Larger cylinder = $9\pi r^2$

(Student shows division to give 7/9)

(6) $a = 5, b = 4$

(7) 10648

(8) $x = -2.5, y = 134$

Questions 15

(1) 8cm

(2)

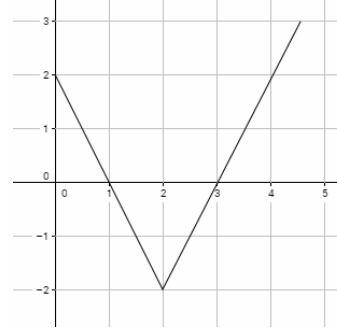

(3) 16%

(4) 10cm

(5) $8\sqrt{3}$

(6) 11.2cm (1 dp)

(7) $\frac{49}{99}$

(8) $\frac{1}{4}$, rule is dividing by $\sqrt{2}$ each time.